

Description

The PAM3N10 uses advanced trench technology and design to provide excellent RDS(ON) with low gate charge. It can be used in a wide variety of applications.

Features

- ◆ VDS = 100V, ID = 3A
RDS(ON) <115mΩ @ VGS=10V
- ◆ High density cell design for ultra low Rds(on)
- ◆ Fully characterized avalanche voltage and current
- ◆ Excellent package for good heat dissipation

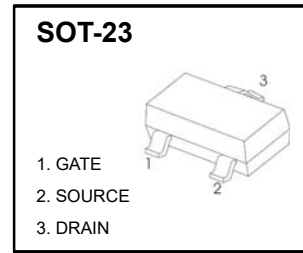

Applications

- ◆ Power switching application
- ◆ Hard switched and high frequency circuits
- ◆ Uninterruptible power supply

Dimensions and Pin Configuration

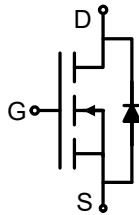

Circuit and Pin Schematic

Marking Information

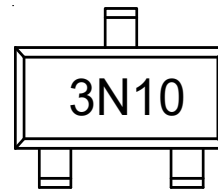

Device Marking Code : 3N10

Absolute Maximum Ratings (TA=25°C unless otherwise specified)

Parameter	Symbol	Limit	Unit
Drain-Source Voltage	V _{DS}	100	V
Gate-Source Voltage	V _{GS}	±20	V
Drain Current-Continuous	I _D	3	A
Drain Current-Pulsed ^(Note 1)	I _{DM}	20	A
Maximum Power Dissipation	P _D	1.25	W
Operating Junction and Storage Temperature Range	T _J , T _{STG}	-55 To 150	°C

Thermal Characteristic

Thermal Resistance, Junction-to-Ambient ^(Note 2)	R _{θJA}	312	°C/W
---	------------------	-----	------

Electrical Characteristics ($T_A=25^{\circ}\text{C}$ unless otherwise specified)

电特性 ($T_A = 25^{\circ}\text{C}$ 除非另有规定)

Electrical Characteristics (Ratings at 25°C ambient temperature unless otherwise specified).

参数 Parameter	符号 Symbols	测试条件 Test Condition	界限 Limits			单位 Unit
			Min	Typ	Max	
Static						
Drain-Source Breakdown Voltage	V(BR)DSS	$V_{GS}=0V, I_D=250\mu A$	100			V
Gate-Threshold voltage (note 3)	V_{GS(th)}	$V_{DS}=V_{GS}, I_D=250\mu A$	1.0	1.6	2.0	V
Gate-body Leakage	I_{GSS}	$V_{DS}=0V, V_{GS}=\pm 20V$			± 100	nA
Zero Gate Voltage Drain current	I_{DSS}	$V_{DS}=80V, V_{GS}=0V$			1	μA
Drain-Source On-Resistance (note 3)	R_{DS(ON)}	$V_{GS}=10V, I_D=3A$			115	m Ω
Forward trans conductance (note 3)	g_{fs}	$V_{DS}=5V, I_D=2.9A$	3			S
Diode forward voltage (note 3)	V_{SD}	$I_S=3A, V_{GS}=0V$			1.2	V
Dynamic (note 4)						
Input capacitance	C_{iss}	$V_{DS}=25V, V_{GS}=0V, f=1MHz$		690		pF
Output capacitance	C_{oss}			120		
Reverse Transfer capacitance	C_{rss}			90		
Total gate charge	Q_g	$V_{DS}=30V, V_{GS}=10V, I_D=3A$		15.5		nC
Gate-source charge	Q_{gs}			3.2		
Gate-drain charge	Q_{gd}			4.7		
Switching (note 4)						
Turn-on Time	t_{d(on)}	$V_{DS}=30V, V_{GS}=10V, I_D=2A, R_G=2.5\Omega, R_L=15\Omega$		11		ns
Rise time	t_r			7.4		
Turn-off Time	t_{d(off)}			35		
Fall time	t_f			9.1		

Notes:

1. Repetitive Rating: Pulse width limited by maximum junction temperature.
2. Surface Mounted on FR4 Board, $t \leq 10$ sec.
3. Pulse Test: Pulse Width $\leq 300\mu s$, Duty Cycle $\leq 2\%$.
4. Guaranteed by design, not subject to production

Typical Characteristics

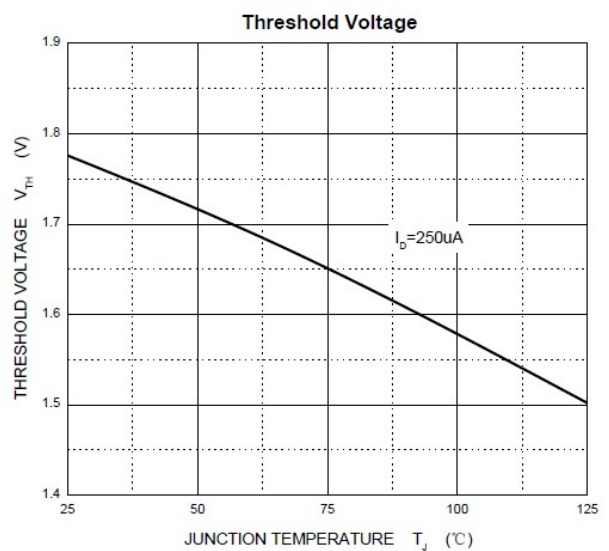
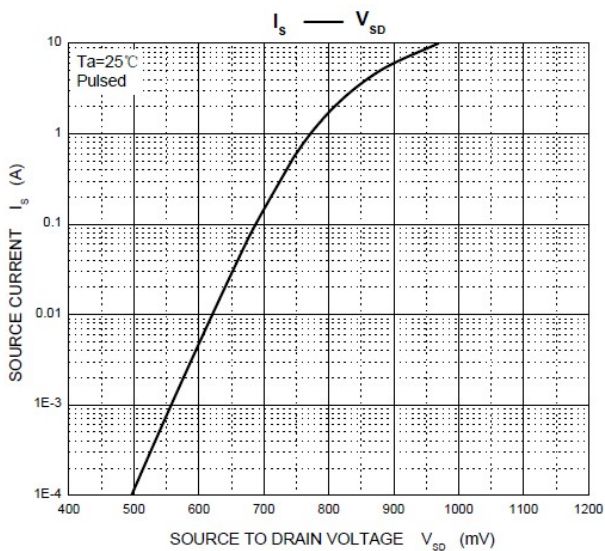
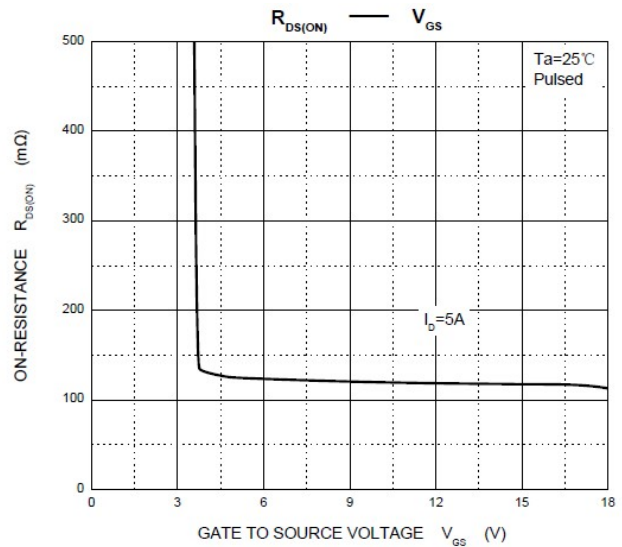
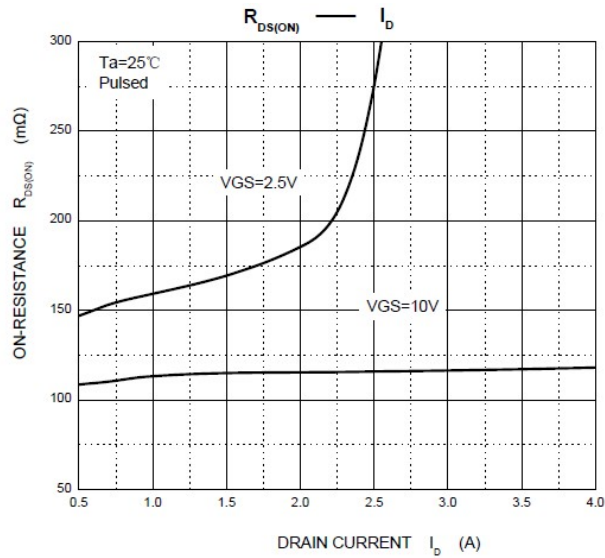
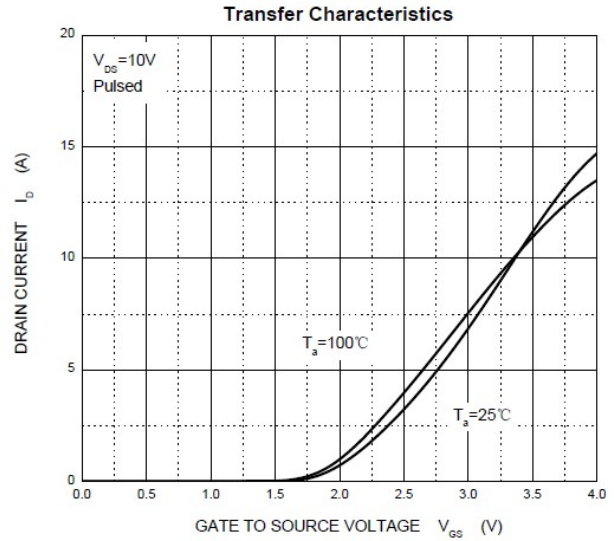
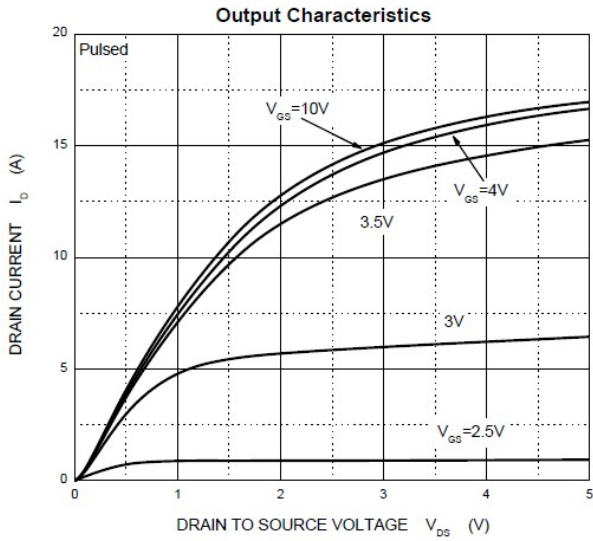

SOT-23 Package Outline Drawing

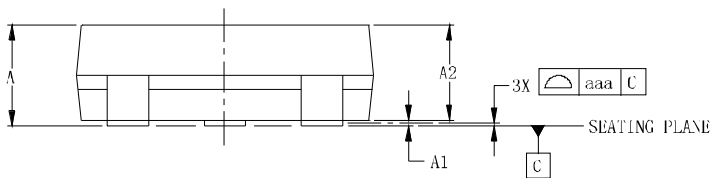
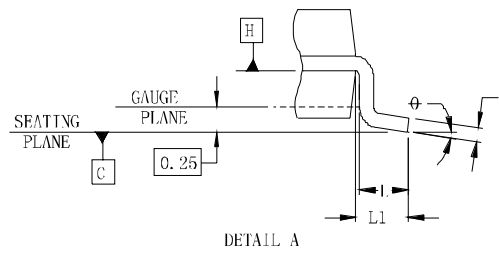
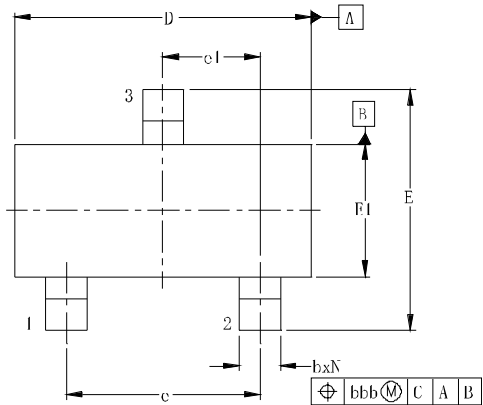

DIMENSIONS						
SYM	INCHES			MILLIMETERS		
	MIN	NOM	MAX	MIN	NOM	MAX
A	0.035	-	0.044	0.89	-	1.12
A1	0.000	-	0.004	0.01	-	0.10
A2	0.035	0.037	0.040	0.88	0.95	1.02
b	0.012	-	0.020	0.30	-	0.51
c	0.003	-	0.007	0.08	-	0.18
D	0.110	0.114	0.120	2.80	2.90	3.04
E	0.082	0.093	0.104	2.10	2.37	2.64
E1	0.047	0.051	0.055	1.20	1.30	1.40
e	0.075			1.90BSC		
e1	0.037			0.95BSC		
L	0.015	0.020	0.024	0.40	0.50	0.60
L1	0.022			0.55		
N	3			3		
ϕ	0°	-	8°	0°	-	8°
aaa	0.004			0.10		
bbb	0.008			0.20		

Suggested Land Pattern

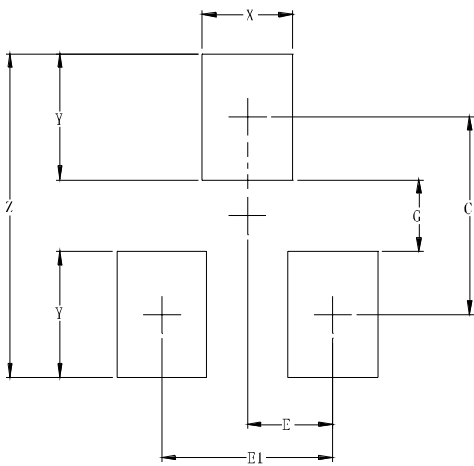

DIMENSIONS		
SYM	INCHES	MILLIMETERS
C	0.087	2.20
E	0.037	0.95
E1	0.075	1.90
G	0.031	0.80
X	0.039	1.00
Y	0.055	1.40
Z	0.141	3.60

Contact Information

Changzhou D-first Electronics CO.,Ltd.

www.first-electronic.com

Email: xhf@first-electronic.cn

Phone: +86 (0519) -8817 1671

Recommended Soldering Conditions

Reflow Soldering

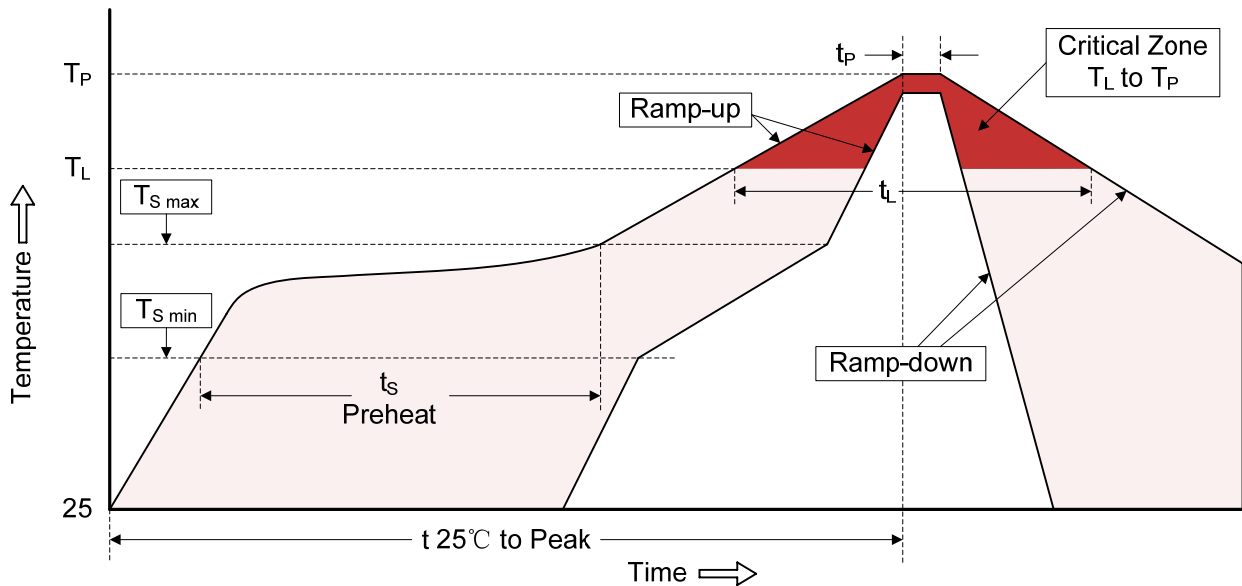

Recommended Conditions

Profile Feature	Pb-Free Assembly
Average ramp-up rate (T_L to T_P)	3°C/second max.
Preheat -Temperature Min ($T_{S\ min}$) -Temperature Max ($T_{S\ max}$) -Time (min to max) (t_s)	150°C 200°C 60-180 seconds
$T_{S\ max}$ to T_L -Ramp-up Rate	3°C/second max.
Time maintained above: -Temperature (T_L) -Time (t_L)	217°C 60-150 seconds
Peak Temperature (T_P)	260°C
Time within 5°C of actual Peak Temperature (t_p)	20-40 seconds
Ramp-down Rate	6°C/second max.
Time 25°C to Peak Temperature	8 minutes max.